

JA-151IR wireless 4beam optical barrier

The JA-151IR four-beam infra-red optical barrier is designed for the indication of a breach into a protected area by crossing the IR line between the transmitter and the receiver. The barrier is a product SL-350QFR by Optex supplemented with transmitters JA-150TX-V4 produced by JABLOTRON ALARMS compatible with the JABLOTRON 100. The device is equipped with a 4-ray optical part with a high immunity against false alarms and the detection of small animals. The barrier occupies two positions in the system. The transmitters regularly perform automatic tests and report their status to the system. The barrier should be installed by a trained technician with a valid certificate issued by an authorised distributor.

Barrier installation

The following instructions should be observed when selecting a place for barrier installation:

- Both units must be installed on a stationary construction (e.g. a wall or a thick post) at the same height and should face each other.
- The area between the barrier units must not be blocked by any bushes or tall grass.
- There can be up to a 100 m distance between the units indoors. (The distance could be reduced outdoors.)
- The receiver unit must not be affected by direct sunlight.
- The units should be installed 0.7 – 1 m above the ground.
- If the IR beam is parallel to a wall, there must be at least a 1 m distance between the beam and the wall.
- If multiple barriers are used, it is necessary to avoid influencing the beam of one barrier by another barrier

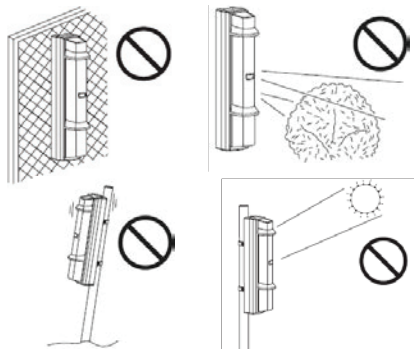

Fig. 1: Undesirable locations

Installation steps:

The transmitting unit (marked TRANSMITTER) and the receiving unit (marked RECEIVER) are of identical mechanical construction.

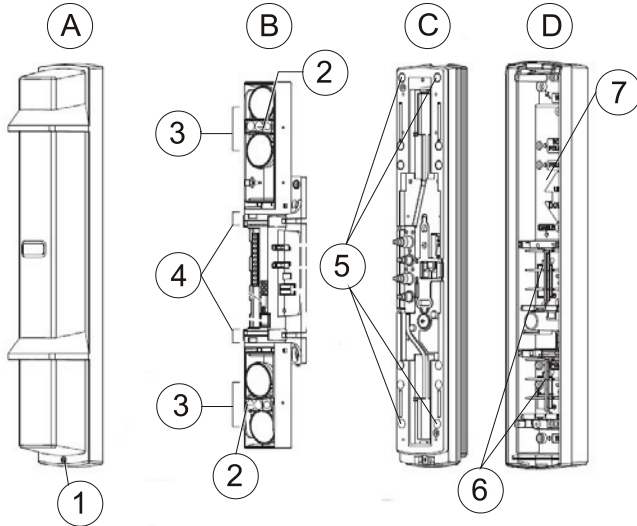

Fig. 2 Barrier parts (identical for transmitter and receiver): A – Front barrier cover, B – Main unit, C – Base of the unit, D – Rear cover, 1 – The locking screw of the front cover, 2 – Viewfinder for barrier alignment, 3 – Optical part, 4 – Setting of optical viewing angle, 5 – Screws for main unit fixing, 6 – Battery holders, 7 – Jablotron transmitter

- Unscrew the front cover screw (1) and remove it. Use a coin inserted between the thresholds of the plastic parts to get it out and carefully take it off by a prying motion.
- Take away the main unit with the base (B+C) by releasing the 4 screws (5) in the corner of the base unit (C). Then take the base of the unit away from the rear cover (D).
- Install the rear cover (D) onto the selected place, either directly onto a wall or a post. On the rear plastic case holes are pre-pressed for installation on the wall (WALL) or for a pole (POLE).

- The Jablotron transmitter (7) and battery holders (6) are placed inside the rear cover (D). Everything is connected to the main unit by a coloured wiring harness with connectors. The connectors are unmistakable.

Enrolling the barrier transmitters into the system

The radio transmitters for communication with the JABLOTRON 100 system are placed inside the rear cover (D) underneath the optical part of the detector. The barrier occupies 2 positions in the system. Barrier activation is reported by the receiving part of the barrier. Both barrier parts report tampering and battery status.

For powering each unit always use a minimum of two SAFT LSH20 lithium batteries (they are not included in the package). The correct position of the batteries is marked inside the holder. Mind the correct polarity during insertion. Four batteries can be inserted into the receiver and transmitter as well. This prolongs the barrier operational time.

- Enrol the radio transmitter to the system.
 - There must be a JA-11xR radio module installed in the system.
 - Go to the **F-Link** software, select the required position in the **Devices** window and launch the enrolment mode by clicking on the **Enrol** option.
 - Insert the batteries (mind the correct polarity). The enrolment signal is transmitted when the first battery is inserted into the detector and the device is enrolled to the selected position.
- Screw on the base (C) and main (B) unit.
- Do the barrier optical alignment according to the following chapter.
- Screw on the cover and test the barrier functioning.

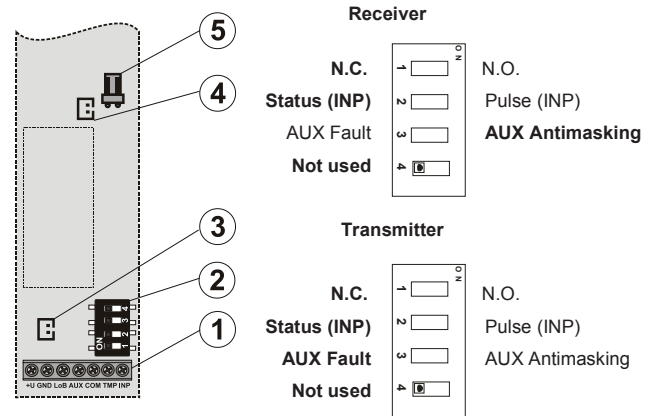

Factory settings highlighted by bold letters.

Fig. 3 Radio transmitter JA-150TX-V4 (matched transmitter and receiver): 1 – terminals, 2 – option DIP switch (factory pre-set), 3 – external tamper connector, 4 – external antenna jumper, 5 – external antenna connector

If needed the transmitter can be equipped with an AN-868 (2PIN) external antenna connected to the connector (5) and disconnect the jumper (4).

Setting up the optical part of the barrier

Always perform the detector settings and beam alignment when the tamper contact is blocked. The optical part of the barrier must be adjusted so that the optical parts facing each other are physically aligned. Both units are equipped with adjusting elements for the adjustment of direction and a view-finder for precise adjustment. The unit opposite the one you want to adjust must be in the centre of the aiming cross and the cross must be in the centre of the view-finder (see fig. 4). There are optical covers placed inside the front barrier covers. Slide the cover on the lower optical part and perform the upper optical part setting then repeat the procedure for the lower part of the optics. If it is needed to test the barrier function with a closed front cover it is possible to lock the tamper contact by a rotating plate to avoid physical closing of the barrier. The rotating plate is placed next to the tamper contact.

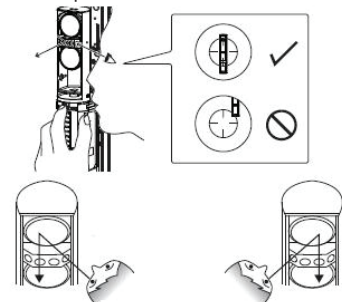

Fig. 4: Setting up the optical part

JA-151IR wireless 4beam optical barrier

When the setting is complete, it is followed by adjustment of the receiver unit:

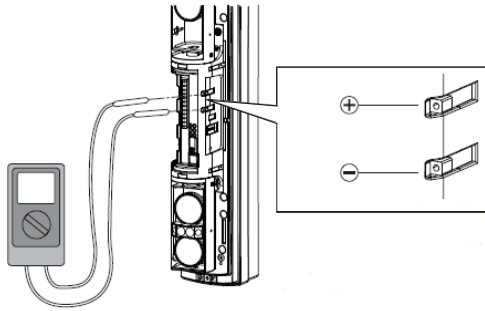

Fig. 5: Setting up using a multimeter

A permanently lit LED on the transmitter/receiver indicates that the beam has been interrupted (or wrongly adjusted). The better the beam reception, the longer the break between the LED flashes – see fig. 8, LED 2. When the LED stops flashing, continue looking for the ideal position indicated by the highest voltage measured on the voltmeter (see fig. 5). The ideal measured value should be **higher than 2.4 V**.

Setting up the electronic part of the barrier

Both units are equipped with settings switches. Each barrier has specific beam modulation so that's why several barriers can be installed near each other. The barriers cannot influence each other.

There is a DIP switch on the receiving unit with six switches. It is possible to set the beam modulation (the setting has to be the same on the receiver as on its partner transmitter). For beam modulation setting see figure 6. For examples of installations, see the original manual in the delivery pack. It is possible to set a 2 minute sleep time after an alarm (beam interruption) in order to save the batteries. The setting is done by switching switch no. 3 to the ON position. The auxiliary output is set by DIP no. 4. **Don't change** this setting, it ensures the correct triggering of the fault status. DIP switches no. 5 and no. 6 determine the reaction sensitivity. See options for settings in fig. 7.

Note: If the beam strength is reduced (less than 50%) for more than 20 s, it triggers a fault and a report is sent to the control panel.

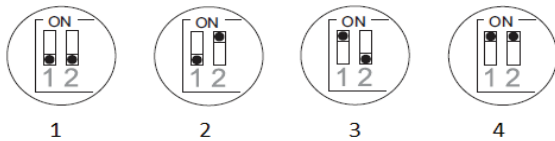

Fig. 6: Beam modulation setting

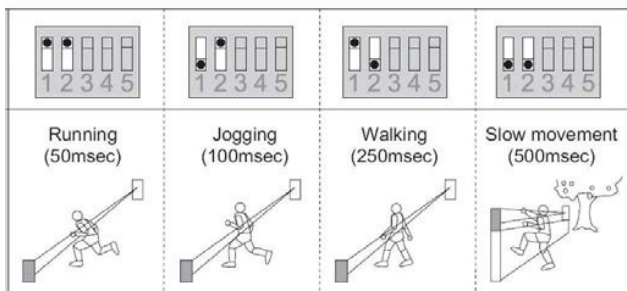

Fig. 7: Reaction time setting

Testing

Perform the barrier test in three places (A, B and C – next to both the units and in the centre). The setting is completed only if the barrier reacts successfully in all three positions. You should also check the signal transmission to the system control panel. Only then is it possible to put back the unit covers and secure them and then perform the final test.

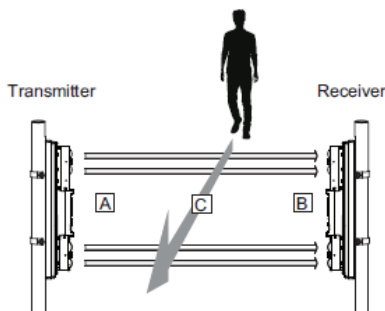

Fig. 8: Barrier function test

The indication LEDs on the units (fig. 8) have the following functions when the tamper is unlocked:

Alarm (1) indicator lights when the beam is interrupted.

Level indicator (2), the better the beam reception, the longer the break between the LED flashes.

Low Battery (3) indicators flash if the batteries in the unit are discharged. Always replace both (all) batteries at the same time. (SAFT LSH20 lithium batteries).

Power (4) indicator- lights when the transmitter unit works.

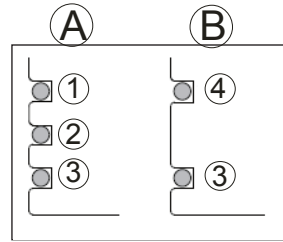

Fig. 9: Indication LEDs in units: A – Receiver, B – Transmitter, 1 – Alarm, 2 – Beam quality Level-indicator, 3 – Low Battery indicator, 4 – Transmitter operation indication (Power)

Replacing the batteries

The detector checks the battery status automatically. Nearly drained battery is reported by continuous flashing of yellow signalling LED on the detector (1 flash per sec) and at the same time low battery status is reported to the control panel. The detector remains fully functional. The battery should be changed as soon as possible.

The control panel must be in service mode **before battery changing** (see the control panel installation manual). Tamper contact must be pressed several times after opening the cover and removing the battery to discharge capacitors. We recommend to use lithium batteries SAFT LSH20 (3.6 V 13 Ah). Always replace all batteries simultaneously. If it is needed to increase the lifetime of the batteries you can add two more batteries. Then you have 4 batteries in one unit.

Technical specifications

Power	4x (8x) LSH20 type lithium batteries (3.6 V/13 Ah)
	Please note: Batteries are not included
Current consumption (nominal/maximal)	765 µA/50 mA
Average battery lifetime	approx. 3 years* (6 years)*
	* with 120 s energy saving mode
Communication band	868.1 MHz, JA-100 protocol
RF range	up to 300 m (open area)
Optex barrier parameters	
Distance between barrier units	max. 100 m
Barrier installation height	0.7 – 1.0 m
Object motion speed	as set by an installer
Enclosure protection	IP65
Max. relative humidity of the environment	95 %
Weight (receiver + transmitter)	3300 g
Operational environment according to EN 50131-1	IV
Operational temperature range	-20 °C to +60 °C
Security grade	according to OPTEX
Complies with	ETSI EN 300220, EN 50130-4, EN 55022, EN 60950-1 ERC REC 70-03

Can be operated according to



JABLOTRON ALARMS a.s. hereby declares that the JA-151IR composed of Optex detector SL-350QFR and radio module JA-150TX-V4 is in a compliance with the relevant Union harmonisation legislation: Directives No: 2014/53/EU, 2014/35/EU, 2014/30/EU, 2011/65/EU. The original of the conformity assessment can be found at www.jablotron.com - Section Downloads.

Note: Although this product does not contain any harmful materials we suggest you return the product to the dealer or directly to the producer after use.

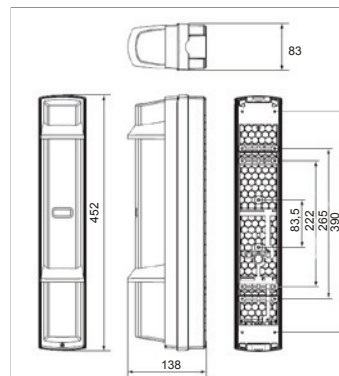

Obr. 10: Dimensions of units