

JA-180W Wireless combined PIR + MW detector

The JA-180W is a component of JABLOTRON 100 alarm system. It is designed to detect human body movement inside buildings. A high immunity to false alarms is reached thanks to the combination of PIR and microwave (MW) detection. The detector guards like a usual PIR detector. If a physical movement is detected in the protected area it also triggers the MW part of the detector and it confirms PIR detector activation. Information is then sent to the control panel. The detector occupies one position in the system. It is designed to be installed by a trained technician with a valid certificate issued by an authorized distributor.

Installation

There should be no obstacles blocking the detector's "view" of the protected area. Keep the detector away from metal objects which could interfere with radio communication and the MW field.

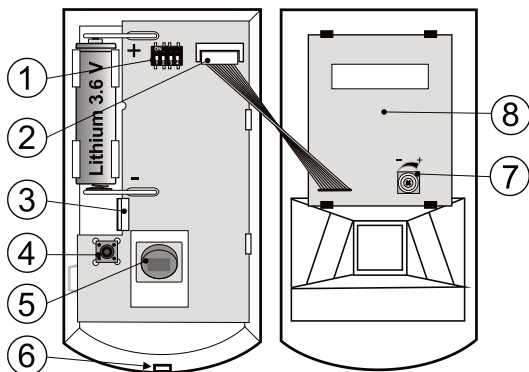

Figure 1: 1. DIP-switch; 2. MW part connector; 3. PCB tab; 4. tamper-switch; 5. PIR sensor; 6. front cover tab; 7. MW sensitivity setting; 8. MW detector

1. Open the detector cover by pressing the tab (6). Avoid touching the internal PIR element (5) – otherwise it can be damaged.
2. Remove the PCB which is held by an internal tab (3). Leave the connector (2) of the MW part.
3. Punch screw holes through the rear plastic cover according to the installation point, either for a corner or for a flat wall. At least one screw should penetrate the tamper-sensitive section.
4. Screw the rear cover to the wall, about 2.5 m above the floor is the recommended installation height (vertically, with the tab down).
5. Put the PCB back till the tab (3) clicks.
6. Leave the cover open and then follow the control panel or receiver installation manual. Basic procedure:
 - a) There must be a JA-11xR radio module installed in the system.
 - b) Go to the **F-Link** software, select the required position in the **Devices** tab and launch the enrollment mode by clicking on the **Enroll** option.
 - c) Insert a battery (mind the correct polarity). When the battery is inserted into the battery holder an enrollment signal is transmitted to the control panel and the detector is enrolled to the selected position. After installing a battery into the detector, allow three minutes for stabilization. During this period the LED is continuously lit.
7. Close the detector cover till the tab (6) clicks.

Notes:

- To enroll a detector after having already connected a battery, first disconnect the battery, and press and release the tamper switch to discharge any remaining charge to ready the device for enrollment.
- The detector can also be enrolled into the system by entering its production code in the F-Link software. You can find the production code on the sticker, glued onto the PCB. All numbers under the bar code shall be entered (1400-00-0000-0001).
- If you need to remove the module from the system, erase it from its position in the control panel.
- To comply with EN 50131-2-4 the tab (6) must be secured by the supplied screw.

Setting DIP switch

Switch no.1: DEL / INS: the position of the DIP switch doesn't matter as the reaction is set by the F-Link SW reaction.

Switch no.2: PIR NORM / HIGH: selection of immunity to false alarms. The **OFF** (NORM) position combines very good immunity with fast sensor reactions. The **ON** (HIGH) position gives increased immunity with a slower reaction time and is only used for problematic installations.

Switch no.3: MW NORM / HIGH sets the time period after PIR detection in which the MW detection is active. The position **OFF** – 1 s, **ON** – 2 s

Switch no.4: MW NORM / TEST. The position **OFF** is for the standard function of the detector. The MW detection is triggered by the PIR detection part for one or two seconds according to switch no.3. The position **ON** - MW detection works continuously for testing purposes (walk test).

Testing the detector

15 minutes after closing the detector cover, the LED indicators show detector activation. A **short flash** of the red light indicates **PIR detection** and a **long flash** (2 sec) indicates **MW confirmation** of the movement.

The MW detector reaction span is from 1 m to up to 15 m. In some cases the detector can detect movement outside the room when obstacles are not metal (such as a thin wall, door, glass, flowing water in plastic pipes, etc.).

For the proper functioning of the detector, it is essential to set the MW detection field according to the place which should be monitored. Generally the MW detection field should be the same as the PIR detection one. For setting up, switch the fourth DIP switch to the **TEST** position. The RF range of the MW part is adjustable by the trimmer (7). Activation of the MW is indicated by a red LED. Because of the environment where the detector is installed and also because of the MW part's detection principle the detection characteristics can be changed according to the room where it is installed, especially by metal objects which cause reflections or shielding the transmitted MW signal. **After setting up, switch the DIP switch no. 4 back to the NORM position!**



Always precisely check the PIR and MW coverage of the protected area during installation.

To save battery energy, the PIR sensor part of the detector switches to battery-save mode 15 minutes after the cover is closed. During battery-save mode the PIR sensor still always detects movement. The first movement detected and consecutively confirmed by the MW part is then signalled to the control panel instantly, and for the next 5 minutes the PIR sensor ignores any further movement (sleep mode). After these 5 minutes, the PIR sensor then returns to watching out for movement until re-triggered.

Battery replacement

The battery condition is regularly checked. If the battery has expired it informs about it by a quick-flashing LED when triggered and it also sends information to the control panel. The battery should be replaced within two weeks by a qualified technician in **SERVICE** mode. After the replacement the detector needs 3 minutes for stabilization – its LED lights up.

Expired batteries should not be thrown into the garbage, but disposed of according to local regulations.

Detection characteristics

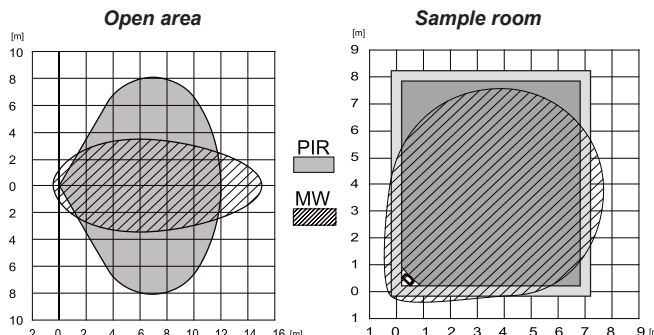

Figure 2: Detection characteristics of PIR and MW coverage in an open area and sample room

Technical parameters

Power supply:	Lithium battery type CR14500 (AA) 3.6 V/2.45 Ah
	Please note: Battery is not included
Nominal current	21 µA
Maximal current	38 µA
Battery low voltage	≤ 2.6 V
Typical battery lifetime:	approx. 2 years (DIP no. 3 to NORM)
Communication band:	868.1 MHz, Jablotron protocol
Communication range:	approx. 300 m
Recommended installation height:	2.0 to 2.5 m above floor level
PIR detection angle/detection range:	110°/12 m (with basic lens)
MW detection angle/detection range:	24°/15 m (open area)
MW detection angle/detection range:	90°/15 m (sample room)
MW detection range / frequency:	9.35 GHz
Dimensions:	110 x 60 x 51 mm
Weight:	114 g
Classification:	Security grade 2/Environmental class II
- according to:	EN 50131-1, EN 50131-2-4, EN 50131-5-3
- operational environment	indoor general
- operational temperature range	-10 °C to +40 °C
- average humidity	75 % RH non condensing
- certification body	Trezor Test s.r.o. (no. 3025)
Complies with	ETSI EN 300 220, ETSI EN 300 440, EN 50130-4, EN 55022, EN 60950-1
	ERC REC 70-03
Can be operated according to	Operation requires notification national telecommunication offices of Finland, France, Italy, Serbia and Montenegro, Spain, Sweden, UK



JABLOTRON ALARMS a.s. hereby declares that the JA-180W is in a compliance with the relevant Union harmonisation legislation: Directives No: 2014/53/EU, 2014/35/EU, 2014/30/EU, 2011/65/EU. The original of the conformity assessment can be found at www.jablotron.com - Section Downloads.

Note: Although this product does not contain any harmful materials we suggest you return the product to the dealer or directly to the producer after use.